

GRANITOGRES TECHNIC

g r è s f i n e p o r c e l l a n a t o



CASALGRANDE
PADANA

Pave your way

GRANITOGRES
TECHNIC
grès fine porcellanato



INDEX

PER L'EDILIZIA INDUSTRIALE FOR INDUSTRY DANS LE BATIMENT INDUSTRIEL KERAMIK FÜR INDUSTRIE	4
RESISTENTE AGLI ACIDI RESISTANT TO ACIDS RESISTANT AUX ACIDES SÄUREBESTÄNDIG	8
FACILE DA PULIRE EASY TO CLEAN EST FACILE A NETTOYER LÄSST SICH LEICHT REINIGEN	12
RESISTENTE ALL'ABRASIONE ABRASION RESISTANT RESISTANT A L'ABRASION ABRIEBFEST	16
SPESSORI THICKNESSES ÉPAISSEURS STÄRKEN	20
CARICO DI ROTTURA BENDING STRENGTH CHARGE DE RUPTURE BRUCHLAST	21
SUPERFICI SURFACES SURFACES OBERFLÄCHEN	22
COLORI COLOURS COULEURS FARBEN	26
FORMATI SIZES FORMATS FORMATE	27
PEZZI SPECIALI TRIMS ACCESSOIRES FORMSTÜCKE	28
CARATTERISTICHE TECNICHE TECHNICAL FEATURES CARACTÉRISTIQUES TECHNIQUES TECHNISCHE EIGENSCHAFTEN	31
PULIZIA PAVIMENTI ANTISCIVOLO CLEANING SLIP-RESISTANT TILED FLOORS NETTOYAGE DES CARREAUX ANTIDÉRAPANTS REINIGUNG VON TRITTSICHEREN BÖDEN	32



Stazioni linea metropolitana Subway stations Stations de métro U-Bahn-Stationen
METRO LE VAL, RENNES (FRA)
Arkansas Roccia / Ontario Roccia / cm 30x30



**PER L'EDILIZIA INDUSTRIALE
FOR INDUSTRY
DANS LE BATIMENT INDUSTRIEL
KERAMIK FÜR INDUSTRIE**



Caseificio Dairy Fromagerie Kaeserei
CASEIFICIO SAN ROMANO, BAISO, REGGIO EMILIA (ITA)
Bianco A Secura / cm 12,5x25

**UN PAVIMENTO INALTERABILE NEL TEMPO
A FLOOR UNTOUCHED BY TIME
UN SOL INALTERABLE DANS LE TEMPS
EIN AUF DAUER BESTÄNDIGER FUSSBÖDEN**

Gli spazi industriali, commerciali, pubblici e simili, sono la "prova del nove" dei materiali per pavimentazione e rivestimento: in questi ambienti infatti tutte le sollecitazioni raggiungono gradi elevatissimi. Ed è proprio in queste condizioni estreme che **Granitogres Technic** dimostra le sue eccezionali qualità di resistenza e semplicità di manutenzione.

Acidi (escluso l'acido fluoridrico), solventi, olii, cemento, sostanze chimiche, non ne modificano minimamente la struttura e l'aspetto; forti carichi statici e dinamici, calpestio, vibrazioni continue, urti, non riescono nè a romperlo nè a scalfirlo; umidità, gelo, fuoco, escursioni termiche abnormi non lo intaccano in nessun modo. Scegliendo opportunamente lo spessore e la superficie delle piastrelle, **Granitogres Technic** rappresenta una soluzione ottimale ed esteticamente sempre valida in molti settori dell'industria, uffici, laboratori e servizi dell'edilizia industriale e civile (aeroporti, ospedali, centri commerciali).

Industrial, commercial, public and other similar areas are the litmus test for paving, flooring and cladding materials, as all the forces and stresses in these environments are at their highest. It is exactly in these extreme conditions that **Granitogres Technic** proves its outstanding properties of resistance and easy maintenance. Acids (with the exception of the hydrofluoric one), solvents, oils, cement and chemicals cannot alter its texture or appearance even to a minimal degree; powerful static and dynamic loads, pedestrian traffic, continuous vibration and impact can neither break nor scratch it; moisture, frost, fire, and anomalous thermal shocks cannot harm it in any way. With the right tile thickness and surface **Granitogres Technic** offers an ideal solution, with outstanding aesthetic results for many areas of industry and for offices, laboratories and a range of both industrial and civil construction applications (airports, hospitals and shopping centres).

Caractérisés par des contraintes très élevées, les espaces industriels, commerciaux, publics et similaires sont la démonstration même de la résistance des matériaux de revêtement sols et murs. C'est justement dans ces conditions extrêmes que **Granitogres Technic** prouve ses exceptionnelles caractéristiques de résistance et de facilité d'entretien. Acides (sauf acide fluorhydrique), solvants, huiles, ciment et agents chimiques ne modifient en aucun cas sa structure et son aspect; les fortes charges statiques et dynamiques, un passage intensif, des vibrations constantes et autres chocs, ne parviennent ni à le casser, ni à le rayer ; de même que l'humidité, le gel, le feu et le choc thermique n'ont aucun effet. Avec une épaisseur et une surface de carreau adéquates, **Granitogres Technic** est la solution idéale, d'un grand effet esthétique, pour de nombreux secteurs industriels, bureaux, laboratoires et constructions du génie industriel et civil (aéroports, hôpitaux, centres commerciaux).

In Industrie-, Gewerbe- und öffentlichen Gebäuden werden Bodenbeläge und Wandverkleidungen auf eine harte Probe gestellt, bei der sie höchster Beanspruchung standhalten müssen.

Granitogres Technic ist durch seine außerordentliche Belastbarkeit und einfache Pflege für solche extremen Bedingungen wie geschaffen. Selbst Säure (mit Ausnahme von Fluorwasserstoff), Lösungsmittel, Öl, Zement und Chemikalien können der Beschaffenheit und dem Aussehen dieses Produkts nichts anhaben. Es hält hohen statischen und dynamischen Lasten, hoher Trittbelastung, anhaltenden Vibrationen und Stößen stand, ohne Schaden zu nehmen. **Granitogres Technic** ist bei Einsatz der angemessenen Fliesenstärke und Oberfläche die optimale Lösung mit ansprechender Ästhetik für viele Industriebranchen, Büros, Labore, Zivil- und Industriegebäuden (Flughäfen, Krankenhäuser, Einkaufszentren).





RESISTENTE AGLI ACIDI
RESISTANT TO ACIDS
RESISTANT AUX ACIDES
SÄUREBESTÄNDIG



Distilleria Distillery Distillerie Brennerei
DISTILLERIA MARZADRO, TRENTO (ITA)
Nevada / cm 20x20

GRANITOGRES È INATTACCABILE
DAGLI AGENTI CHIMICI
QUALI ACIDI, BASI, SALI, ETC

GRANITOGRES IS IMMUNE
TO ATTACK BY AGGRESSIVE AGENTS:
ACIDS, BASES, SALTS, ETC

GRANITOGRES EST INATTAQUABLE
PAR LES AGENTS AGRESSIFS TELS
QUE ACIDES, BESES, SELS, ETC

GRANITOGRES IST BESTÄNDIG
GEGENÜBER MEDIEN WIE SÄUREN, LAUGEN,
SALZEN USW

Granitogres Technic è la soluzione ideale per tutti gli ambienti industriali e laboratori in cui sia indispensabile una particolare resistenza ad acidi, basi e agenti corrosivi. Le prove effettuate secondo la norma UNI EN ISO garantiscono la assoluta resistenza di **Granitogres** alle aggressioni chimiche, ad eccezione dell'acido fluoridrico che attacca tutti i materiali ceramici.

Granitogres Technic is the ideal solution for all industrial environments and laboratories where superior resistance to acids, alkalis and corrosive compounds is essential. Tests conducted in accordance with the UNI EN ISO standard are a guarantee that **Granitogres** is totally resistant to all chemicals with the exception of hydrofluoric acid, which is harmful to all ceramics.

Granitogres Technic est la solution idéale en milieu industriel et en laboratoire, où un tel produit doit s'avérer particulièrement résistant aux acides, bases et autres agents corrosifs. Les essais réalisés selon la norme UNI EN ISO garantissent une résistance totale de **Granitogres** aux agents chimiques, à l'exception de l'acide fluorhydrique qui attaque tous les matériaux céramiques.

Granitogres Technic ist die ideale Lösung für die Industrie und für Labore, in denen Bodenbeläge und Wandverkleidungen gegen Säuren, Laugen und korrosive Stoffe besonders beständig sein müssen. Prüfungen gemäß UNI EN ISO zufolge ist **Granitogres**, mit Ausnahme von Fluorwasserstoff, der bekanntlich alle keramischen Materialien angreift, gegen Chemikalien beständig.





Cantina vitivinicola Winery Case vinicole Weinkellerei
TERRE DA VINO, BAROLO, CUNEO (ITA)
Nebraska / cm 20x20



**FACILE DA PULIRE
EASY TO CLEAN
EST FACILE A NETTOYER
LÄSST SICH LEICHT REINIGEN**

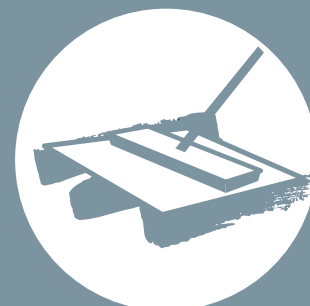

**INASSORBENTE,
FACILITA OGNI OPERAZIONE DI PULIZIA
ABSORBS NOTHING,
SO CLEANING COULDN'T BE EASIER
NON ABSORBANT FACILITE TOUTE
OPERATION DE NETTOYAGE
IST NICHT SAUGFÄHIG UND BEGÜNSTIGT
DAHER EINE LEICHTE REINIGUNG**

Granitogres Technic è ideale per quei settori industriali, come il farmaceutico e l'alimentare, che sono sottoposti a normative igieniche molto severe.

L'assoluta impermeabilità della piastrella la rende praticamente inattaccabile dalle macchie, mentre batteri e muffe possono essere facilmente rimossi.

Granitogres Technic is ideal for industrial sectors, such as the pharmaceutical and foodstuffs industries, subject to particular stringent hygiene regulations.

The total impermeability of the tile makes it practically unstainable, while bacteria and moulds are easily removable.

Granitogres Technic est la solution idéale en milieu industriel : les secteurs pharmaceutiques et alimentaires doivent, par exemple, respecter des réglementations très strictes en matière d'hygiène.

La totale imperméabilité des carreaux en fait un produit à la fois pratique et résistant pratiquement à toutes les taches, tandis que bactéries et autres moisissures seront facilement éliminées.

Granitogres Technic ist ideal für alle Industriebranchen, die wie die Pharma- und Lebensmittelindustrie strengen Hygienevorschriften unterliegen. Die absolute Undurchlässigkeit der Fliesen gewährt zuverlässigen Schutz gegen Flecken. Bakterien und Schimmel sind leicht zu entfernen.



Centro commerciale shopping centre Centre commerciaux Einkaufszentren
AKADEM PARK, ST. PETERSBURG (RUS)

Nebraska / Arkansas / Ontario / Bianco B / Grigio cenere / cm 15x15, 30x30



Centro commerciale shopping centre Centre commerciaux Einkaufszentren
AKADEM PARK, ST. PETERSBURG (RUS)
Nebraska / Arkansas / Ontario / Bianco B / Grigio cenere / cm 15x15, 30x30



RESISTENTE ALL'ABRASIONE
ABRASION RESISTANT
RESISTANT A L'ABRASION
ABRIEBFEST



Struttura ospedaliera Hospital Hôpital Krankenhaus
EMERGENCY "SALAM" SURGEY CENTER, KHARTOUM (SUN)
Nebraska / cm 30x30

GRANITOGRES TECHNIC PRESENTA
OMOGENEITÀ CROMATICA E DI STRUTTURA
FRA SUPERFICIE ED INTERNO, MENTRE
LA NORMALE PIASTRELLA SMALTATA
PRESENTA DISCONTINUITÀ FRA LO STRATO
SUPERFICIALE E LO STRATO INTERNO
GRANITOGRES TECHNIC IN VITRIFIED
STONEWARE THE COLOUR AND STRUCTURE
OF THE SURFACE AND THE INTERIOR ARE
EXACTLY THE SAME. WITH ORDINARY
GLAZED TILES THE SURFACE LAYER IS VERY
DIFFERENT FROM WHAT LIES BELOW

GRANITOGRES TECHNIC PRESENTE
 HOMOGENEITE CHROMATIQUE ET DE
 STRUCTURE ENTRE LA SURFACE ET
 L'INTERIEUR, TANDIS QUE LE CARREAU EMAILLE
 PRESENTE DISCONTINUTE ENTRE LA COUCHE
 SUPERFICIELLE ET LA COUCHE INTERIEURE
MERKMAL VON GRANITOGRES TECHNIC
 IST IHRE FARB- UND GEFÜGEHOMOGENITÄT
 VON OBERFLÄCHE UND GRUNDMASSE,
 WÄHREND HERKÖMMLICHE GLASIERTE FLIESEN
 EINEN SPRUNGHAFTE ÜBERGANG ZWISCHEN
 DIESEN BEIDEN SCHICHTEN AUFWEISEN

Granitogres Technic ha superficie e massa della piastrella identiche. Ciò produce effetti positivi sia sulle prestazioni che sulla durevolezza della superficie rivestita. La rimozione dello strato superficiale, dovuta all'uso, porta infatti alla luce una superficie identica alla precedente senza conseguenze sulle caratteristiche estetiche e funzionali del rivestimento orizzontale o verticale.

Granitogres Technic tiles have completely uniform surface and body. This improves both the performance and the durability of the tiled surface. The erosion of the surface layer by wear simply exposes an identical underlying surface, with no effects whatsoever on the appearance and performance of the tile, whether used for wall cladding, flooring or paving.

La surface et la masse des carreaux **Granitogres Technic** sont identiques. Cela se traduit par des performances renforcées et une durabilité accrue de la surface couverte. L'abrasion de la couche superficielle, laisse en effet apparaître une surface identique à la précédente, sans modifier le moins du monde les caractéristiques esthétiques et fonctionnelles du revêtement sol ou mur.

Masse und Oberfläche der Fliesen sind bei **Granitogres Technic** identisch. Dies verbessert sowohl die Eigenschaften als auch die Dauerhaftigkeit des Materials. Der Abrieb der Oberflächenschicht wegen normalen Gebrauchs beeinträchtigt weder das Aussehen noch die Eigenschaften des Bodenbelags oder der Wandverkleidung, da sich die darunter liegende Fläche in nichts von der abgetragenen unterscheidet.





SPESSORI THICKNESSES ÉPAISSEURS STÄRKEN

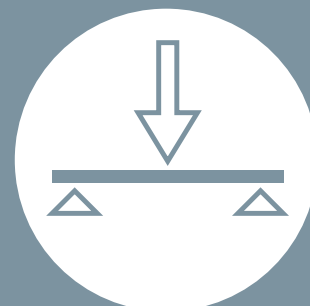

Quando si progetta una pavimentazione industriale, il requisito basilare è la capacità di sopportare carichi sia statici che dinamici che possono raggiungere livelli elevatissimi. La piastrella diventa l'elemento portante e il suo spessore gioca un ruolo fondamentale.

Granitogres Technic è prodotto in 3 diversi spessori: 8 mm - 11,3 mm - 14,2 mm, e in 4 formati che vanno da 15x15 cm a 30x30 cm. Consente così al progettista grande versatilità d'impiego in ogni tipo d'ambiente.

When designing an industrial floor, a basic prerequisite is the ability to withstand both static and dynamic loads which in this environment may reach extremely high levels. The tile itself acts as the supporting structure and its thickness therefore plays a determining role.

Granitogres Technic is available in three different thicknesses: 8 mm, 11.3 mm and 14.2 mm, and in four sizes ranging from 15x15 cm to 30x30 cm, thus offering the project designer total versatility to suit any environment.

Lorsqu'on conçoit un dallage industriel, la première condition à respecter est sa capacité à supporter des charges très importantes, qu'elles soient statiques ou dynamiques. Le carreau devient l'élément portant et son épaisseur joue un rôle fondamental.

Granitogres Technic est disponible en 3 épaisseurs différentes: 8 mm - 11,3 mm - 14,2 mm, et en 4 formats du 15x15 cm au 30x30 cm. L'architecte bénéficiera ainsi d'une grande liberté de choix, quel que soit le type d'espace à revêtir.

Die Grundvoraussetzung bei der Planung eines Industriebodens ist die Festigkeit gegen zum Teil außerordentlich hohe, dynamische und statische Lasten. Die Fliese wird zum tragenden Element, wodurch der Fliesenstärke eine entscheidende Bedeutung zukommt.

Granitogres Technic ist in 3 verschiedenen Stärken (8 mm - 11,3 mm - 14,2 mm) und in 4 Formaten (von 15x15 cm bis 30x30 cm) erhältlich. Dem Planer bietet sich somit eine große Auswahl an möglichen Anwendungen in jedem Bereich.

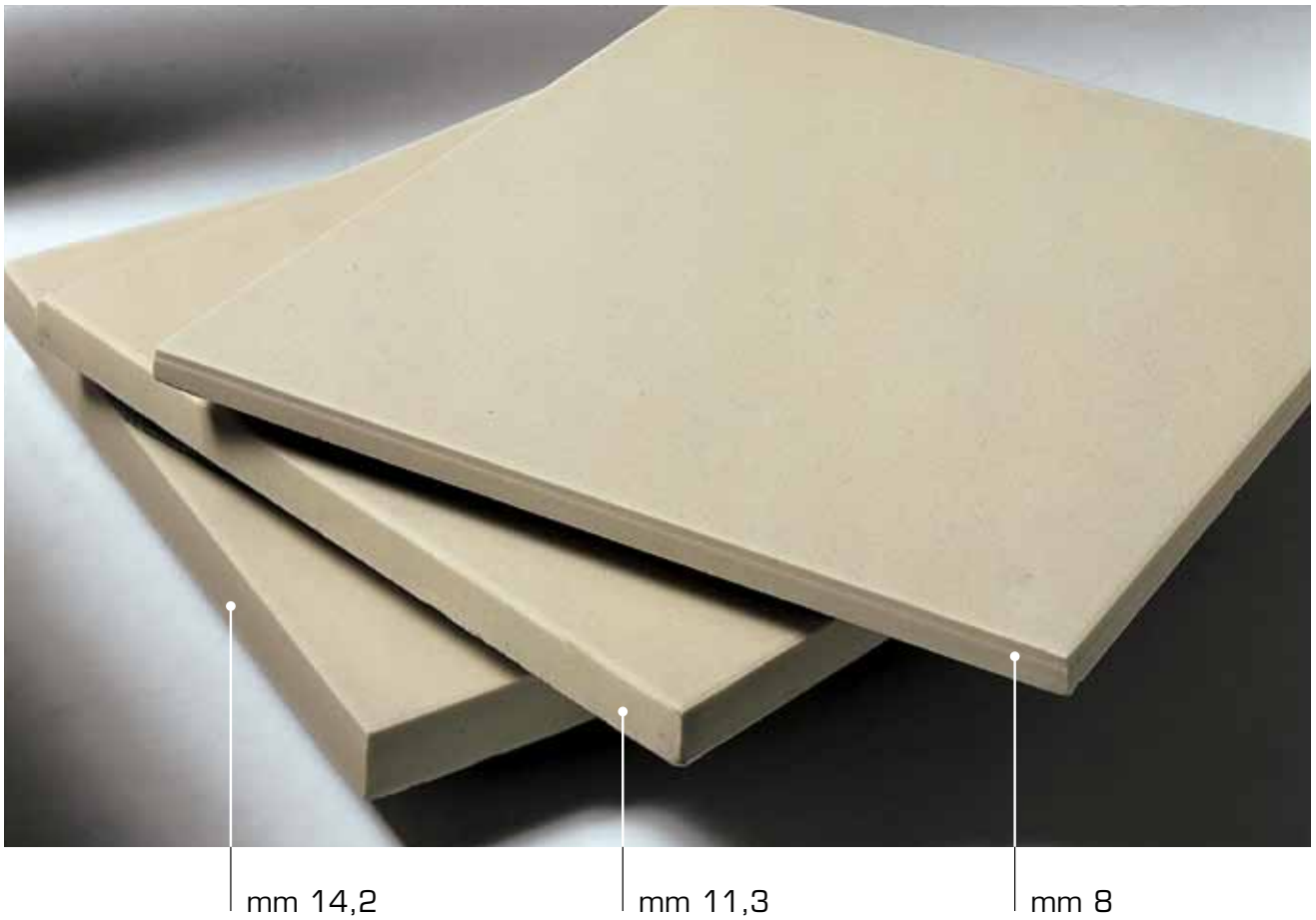

mm 14,2

mm 11,3

mm 8

CARICO DI ROTTURA* **BENDING STRENGTH***
CHARGE DE RUPTURE* **BRUCHLAST***

KG

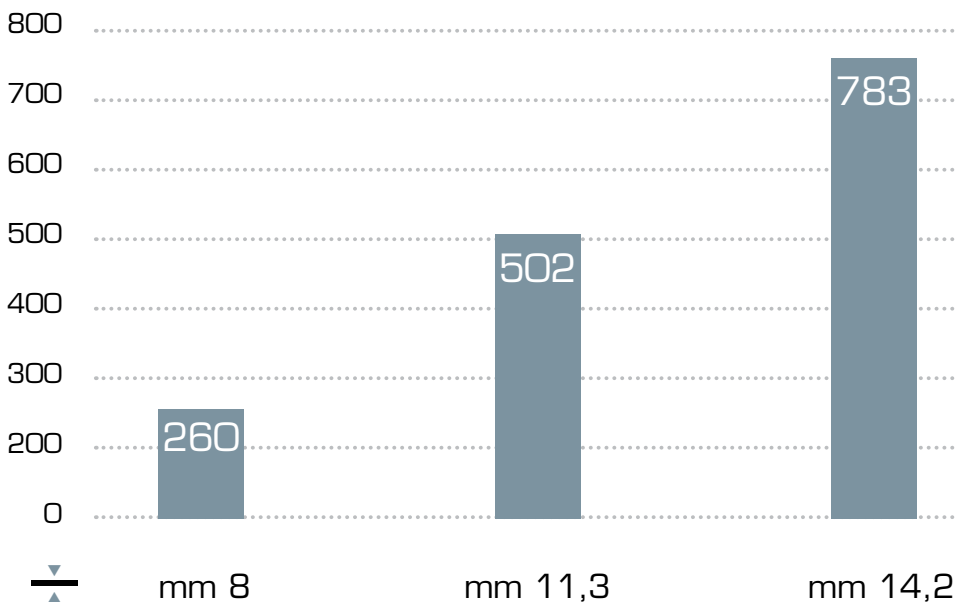

* Prova effettuata su 20x20 cm serie Granito 1 Sahara.

Test performed on 20x20 cm Granito 1 series, Sahara type.

Essai effectué sur 20x20 cm. Série Granito 1 type Sahara.

Prüfung: Bodenfliesen 20x20 cm Serie Granito 1 Typ Sahara.

SUPERFICI SURFACES SURFACES OBERFLÄCHEN



Un contributo determinante all'eliminazione del rischio di scivolosità in ambienti in cui questo rischio è presente, è dato dall'impiego di pavimenti antiscivolo realizzati con **Granitogres Technic** a superficie strutturata.

Casalgrande Padana offre diversi tipi di superfici strutturate, in grado di rispondere ad ogni condizione e necessità di impiego.

In areas with a high risk of slipping, the installation of non-slip flooring realised with **Granitogres Technic** textured surfaces significantly reduces this risk.

Casalgrande Padana offers a variety of different textured surfaces to cater for all possible application conditions and requisites.

La pose de dallages antidérapants, réalisés avec des carreaux **Granitogres Technic** à surface structurée permet de supprimer tout risque de glissement dans des espaces où celui-ci est présent.

Casalgrande Padana propose différents types de surfaces structurées, en mesure de répondre à toute condition d'utilisation.

Granitogres Technic mit strukturierter Oberfläche beseitigt die Rutschgefahr in entsprechend gefährdeten Bereichen.

Casalgrande Padana bietet unterschiedliche Ausführungen von strukturierten Oberflächen an, die allen diesbezüglichen Bedingungen und Anwendungsanforderungen gerecht werden.

Agli effetti delle proprietà antiscivolo dei pavimenti in ambienti di lavoro a piedi calzati si fa riferimento alla norma tedesca DIN 51130 largamente recepita nei capitolati di molti paesi. Qui di seguito riportiamo la sintesi degli indicatori che misurano la resistenza alla scivolosità:

R - indica l'angolo di inclinazione raggiunto nel test di prova (vedi tab. 1)

V - rappresenta lo spazio di deflusso determinato dai rilievi della superficie (vedi tab. 2)

A.B.C. - sono riferimenti di resistenza alla scivolosità relativa ad ambienti umidi e a piedi nudi (**C** = massima proprietà antiscivolo) (vedi tab. 3) (norma tedesca DIN 51097)

The shodfeet German standard DIN 51130, which is widely recognised and integrated in the legislature of many countries, has been used in defining the non-slip properties of flooring in working places. The following is a summary of the indicators used to measure the coefficient of friction:

R - the angle of slope attained during the test (see tab. 1)

V - the displacement space calculated from the surface relief pattern (see tab. 2)

A.B.C. - they indicate the slip resistant properties in wet barefoot areas (**C** = maximum slip prevention) (see tab. 3) (german standard DIN 51097)

La détermination des propriétés antidérapantes des dallages en milieu professionnel à pieds chaussés se réfère à la norme allemande DIN 51130, largement reconnue par les lois de nombreux pays. Vous trouverez ci-après un résumé des facteurs utilisés pour déterminer le coefficient de frottement :

R - l'angle d'inclinaison atteint au cours de l'essai (voir tab. 1)

V - l'espace de refoulement déterminé par les reliefs de la surface (voir tab. 2)

A.B.C. - indiquent la résistance au glissement dans des zones mouillées pieds nus (**C** = propriété antidérapante maximale) (voir tab. 3) (norme allemande DIN 51097)

Die Rutschhemmung der Bodenbeläge in Arbeitsbereichen mit beschuhten Füßen wird gemäß DIN 51130 ermittelt, die in vielen Ländern in den Lastenheften vorgeschrieben wird. Im folgenden eine Zusammenfassung der Indikatoren zur Messung der Rutschhemmung:

R - bezeichnet den Neigungswinkel, der beim Test erreicht wurde (siehe Tab. 1)

V - bezeichnet den Verdrängungsraum, der sich aus den Oberflächenausbildungen ergibt (siehe Tab. 2)

A.B.C. - bezeichnen den Rutschhemmungsgrad in barfuss begangenen Nassbereichen (**C** = höchster Rutschhemmungsgrad) (siehe Tab. 3) (DIN 51097)

TAB. 1

Angolo di inclinazione nel piano di posa



Oltre 6° e fino a 10°

Gruppo di valutazione
Evaluation category
Groupe d'évaluation
Beurteilungsgruppe

R 9



Oltre 10° e fino a 19°

R 10



Oltre 19° e fino a 27°

R 11



Oltre 27° e fino a 35°

R 12



Oltre 35°

R 13

TAB. 2

Gruppo di valutazione
Evaluation category
Groupe d'évaluation
Beurteilungsgruppe

V 4

Volume cavità deflusso
Run-off cavity volume
Volume cavité d'écoulement
Wasserableitende vertiefung



V 6

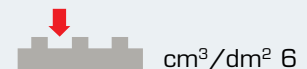

V 8



V 10

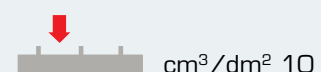

TAB. 3

Gruppo di valutazione
Evaluation category
Groupe d'évaluation
Beurteilungsgruppe

Angolo di inclinazione nel piano di posa

0



< 12°

A



≥ 12°

B



≥ 18°

C



≥ 24°

SUPERFICI SURFACES SURFACES OBERFLÄCHEN

Tipi di superficie con l'indicazione del grado di antiscivolosità secondo il metodo DIN 51130*
 Surfaces types and relative slip prevention properties determined in accordance with DIN 51130 methods*
 Types de surface avec indication des propriétés antidérapantes selon la norme DIN 51130*
 Oberflächenarten mit Angabe des Rutschhemmungsgrads gemäß DIN 51130*



Technic R10



Roccia R12 (A+B)



Profil R12 - V8 (A+B+C)



Reticolo R12 - V4 (A+B+C)



Carbo R12



Secura R11 (A+B)

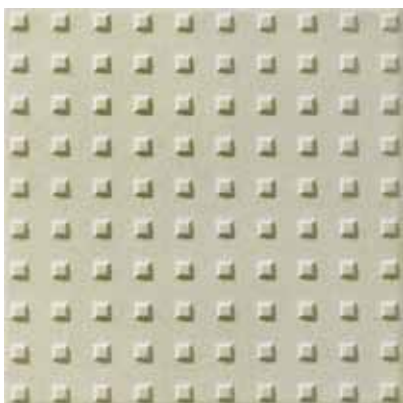

Bugnato R11 - V6 (A+B+C)



Pavè R11 - V4 (A+B+C)



Safe Agréé par la CNAMTS R13

* Vedi a pagina 23 See on page 23 Voir à la page 23 Siehe auf Seite 23

Sono sinteticamente illustrati, a titolo esemplificativo, alcuni suggerimenti di impiego per ognuna delle superfici del nostro catalogo. La norma Din prevede tuttavia una esemplificazione più vasta e completa delle esigenze in una molteplicità di situazioni ambientali.

As examples only, a number of suggested applications for each of the surfaces in our catalogue. The DIN standard itself provides a comprehensive definition of the requisites for an extensive range of situations.

A titre d'exemple, quelques suggestions d'utilisation pour chaque surface de notre catalogue. La norme Din donne, toutefois, une définition plus exhaustive et complète des exigences, et ce, dans une multitude d'espaces différents.

Beispiele für die Einsatzmöglichkeiten der in unserem Katalog angebotenen Oberflächen angegeben. Die Unterteilung der Anforderungen in einer Vielzahl an Einsatzbereichen gemäß DIN ist jedoch detaillierter und vollständiger.

SUPERFICIE TECHNIC SURFACE TECHNIC SURFACE TECHNIC OBERFLÄCHE TECHNIC

Ambienti coperti (uffici, abitazioni, ingressi) con esclusione di quelli umidi.
Indoor use (offices, homes, entrance foyers) with the exclusion of damp places.
Locaux couverts (bureaux, habitation, entrées) à l'exception des locaux humides.
Innenräume (Büros, Wohnungen, Eingänge) mit Ausnahme von feuchten Umgebungen.

SUPERFICIE ROCCIA ROCCIA SURFACE SURFACE ROCCIA OBERFLÄCHE ROCCIA

Terrazze, porticati, marciapiedi, spiagge piscine e in genere pavimenti con presenza di liquidi.
Balconies, porticos, pavements, pool decks, floor surfaces affected by liquids in general.
Terrasses, porches, trottoirs, plages de piscines et, en général, sols en présence de liquides.
Terrassen, Portikusstrukturen, Bürgersteige, Beckenumgänge, Bodenbeläge im allgemeinen, mit Vorhandensein von Flüssigkeit.

SUPERFICIE PROFIL/RETICOLO PROFIL/RETICOLO SURFACE SURFACE PROFIL/RETICOLO OBERFLÄCHE PROFIL/RETICOLO

Cucine di collettività e in genere, pavimenti in ambienti per la lavorazione prodotti alimentari.
Large-scale and industrial kitchens in general, floors where food products are prepared.
Cuisines de collectivités et, en général, sols des locaux de préparation des produits alimentaires.
Großküchen und Küchen im allgemeinen, Bodenbeläge in Räumen, wo Lebensmittel verarbeitet werden.

SUPERFICIE CARBO CARBO SURFACE SURFACE CARBO OBERFLÄCHE CARBO

Locali per il ricevimento e la vendita di pesce e carne, cucine per collettività e simili, esterni anche con pendenza, piazze.
Places where fish and meat are received and sold, industrial kitchens and similar, outdoors slopes, squares.
Locaux de réception et de vente du poisson et de la viande, cuisines des collectivités et similaires, extérieurs même avec pente, places.
Räume für den Empfang und den Verkauf von Fleisch und Fisch, Großküchen und ähnliche Räume, Sowie Aussenbereiche mit Neigungswinkel, Plätze.

SUPERFICIE SECURA SECURA SURFACE SURFACE SECURA OBERFLÄCHE SECURA

Ambienti industriali in genere e spiagge piscine.
Industrial environments in general and pool decks.
Locaux industriels en général et plages de piscines.
Industrieräume im allgemeinen und Beckenumgänge.

SUPERFICIE BUGNATO BUGNATO SURFACE SURFACE BUGNATO OBERFLÄCHE BUGNATO

Spiagge piscine, pavimenti per ambienti di lavorazione prodotti alimentari e simili.
Swimming pool surrounds, places where food products are processed and similar.
Bordures de piscines, locaux de préparation des produits alimentaires et similaires.
Schwimmbadrande, Räume, in denen Lebensmittelprodukte verarbeitet werden, und ähnliches.

SUPERFICIE PAVÈ PAVÈ SURFACE SURFACE PAVÈ OBERFLÄCHE PAVÈ

Porticati, marciapiedi, spiagge piscine, spogliatoi, in genere pavimenti con presenza di liquidi.
Porticos, pavements, swimming pool decks, floor surfaces affected by liquids in general.
Porches, trottoirs et, plages de piscines, sols en présence de liquides.
Portikusstrukturen, Bürgersteige, Beckenumgänge, Bodenbeläge in Räumen.

SUPERFICIE SAFE SAFE SURFACE SURFACE SAFE OBERFLÄCHE SAFE

Reparti taglio, macelleria, salumeria, cucine, panetteria-pasticceria, pescheria.
Cutting, delicatessen, bread and pastry making, butcher's and fishmonger's departments and kitchens.
Ateliers de découpe, boucherie, charcuterie, cuisines, boulangerie-pâtisserie, poissonnerie.
Schneidabteilungen, Schlachtereie, Wurstherstellung, Küchen, Bäckerei, Konditorei, Fischabteilung.

COLORI
COLOURS
COULEURS
FARBEN



Nebraska



Sahara



Arkansas



Georgia

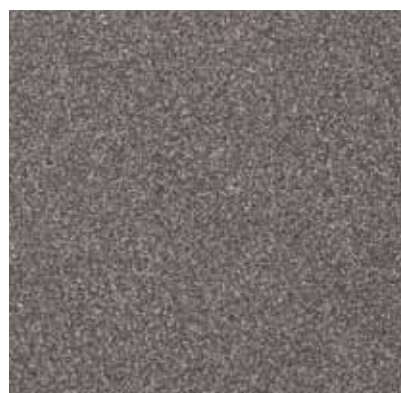

Ontario

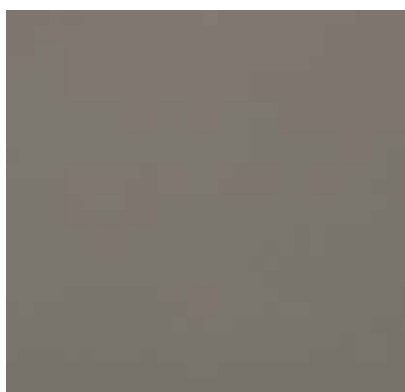

Grigio cenere



Bianco avorio



Bianco B



Colorado

Serie Landscape

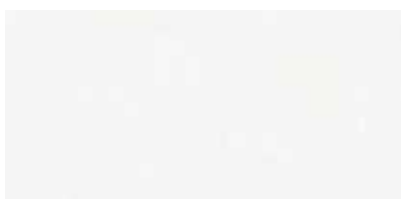



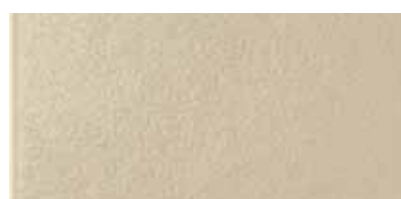











Tundra 100





Beach 101

FORMATI SIZES FORMATS FORMATE

GRES PORCELLANATO NON SMALTATO UNGLAZED PORCELAIN STONEWARE
GRÉS CÉRAME NON ÉMAILLÉ UNGLASIERTE FEINSTEINZEUGFLIESEN

					
	cm 15x15 6"x6"	cm 20x20 8"x8"	cm 12,5x25 5"x10"	cm M12,5x25 [▲] 12"x12"	cm 30x30
ROCCIA  mm		14,2 11,3 8	8	14,2 11,3	14,2 11,3 8
BUGNATO  mm		14,2 11,3 8			
PROFIL  mm	11,3 8	14,2 11,3 8			
PAVÈ  mm		14,2 11,3 8			
SECURA  mm	11,3** 8	14,2 11,3 8	8	14,2 11,3	14,2 11,3 8
CARBO  mm		11,3* 8			
TECHNIC  mm	11,3 8	14,2 11,3 8	8	14,2 11,3	14,2 11,3 8
RETICOLO  mm	11,3** 8	14,2** 11,3 8			
SAFE  mm		11,3*** 8			

GRES PORCELLANATO SMALTATO GLAZED PORCELAIN STONEWARE
GRÉS CÉRAME ÉMAILLÉ GLASIERTE FEINSTEINZEUGFLIESEN

	
SERIE LANDSCAPE	cm M12,5x25 [▲] 5"x10"
SATIN  mm	8
LUCIDA  mm	8

[▲] Dimensioni di fabbricazione mm 118x243. La modularità si ottiene con una fuga di 7 mm.
Factory size mm 118x243. For modular laying, install with a 7 mm joint.
Dimensions de fabrication mm 118x243. Calpinage avec un joint de 7 mm.
Fertigungsgröße mm 118x243. Die Modularität wird mit einer 7 mm Füge erzielt.

* Produzione nei colori:
Currently produced in the following colours:
Production dans les couleurs :
Lieferbar in den Farben:

Bianco avorio

** Produzione nei colori:
Currently produced in the following colours:
Production dans les couleurs :
Lieferbar in den Farben:

Nebraska, Arkansas

*** Produzione nei colori:
Currently produced in the following colours:
Production dans les couleurs :
Lieferbar in den Farben:

Bianco avorio, Bianco B

PEZZI SPECIALI TRIMS ACCESSOIRES FORMSTÜCKE

MODULO **M12,5x25**

SISTEMA CANALETTA 1 CHANNEL SYSTEM 1 SYSTEME CANIVEAU 1 RINNESYSTEM 1

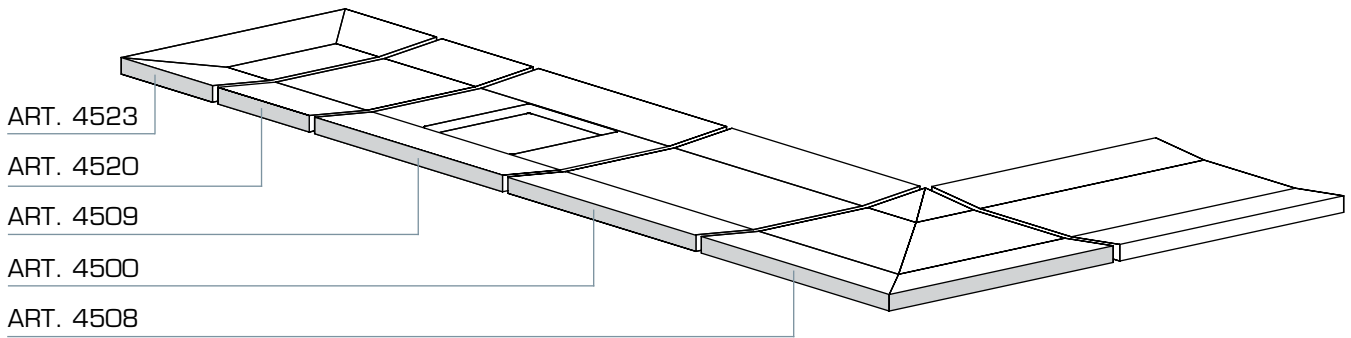

ART. 4523

ART. 4520

ART. 4509

ART. 4500

ART. 4508

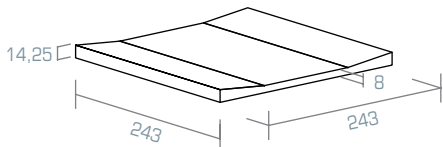

ART. 4500

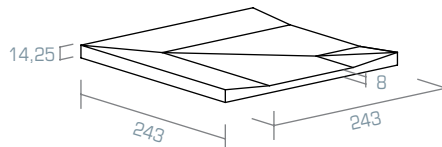

ART. 4508

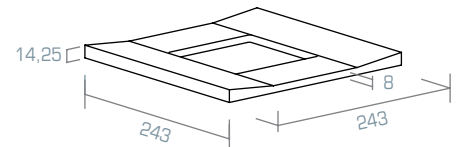

ART. 4509

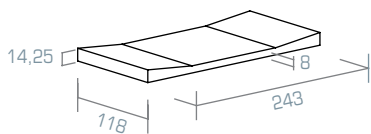

ART. 4520

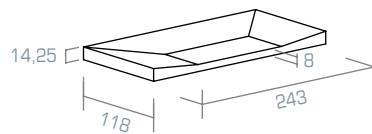

ART. 4523

Colori: Colours:
Couleurs : Farben:
Bianco avorio, Bianco B
Superficie: Surface:
Surface : Oberfläche:
Grip

SISTEMA CANALETTA 2 CHANNEL SYSTEM 2 SYSTEME CANIVEAU 2 RINNESYSTEM 2

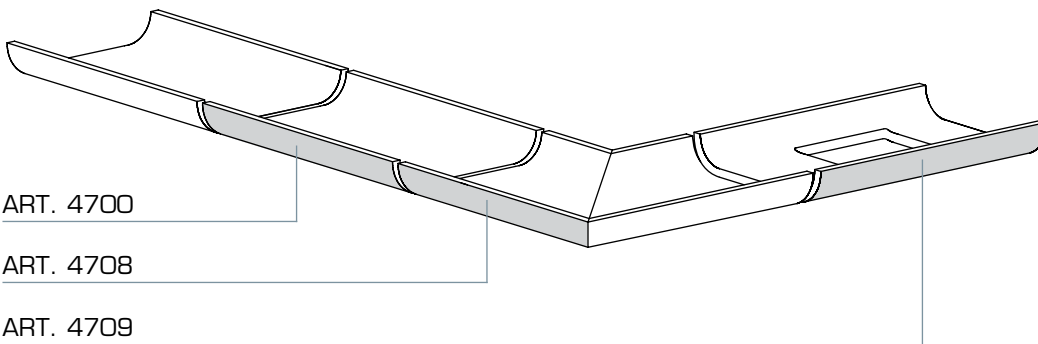

ART. 4700

ART. 4708

ART. 4709

Colori: Colours:
Couleurs : Farben:
Tundra 100
Superficie: Surface:
Surface : Oberfläche:
Satin

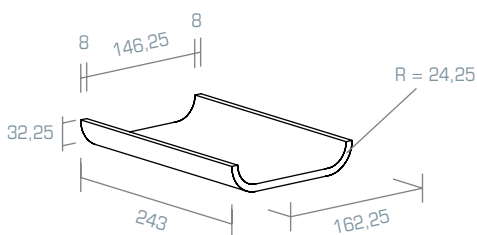

ART. 4700

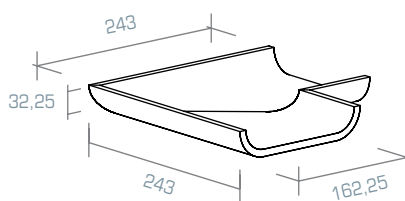

ART. 4708

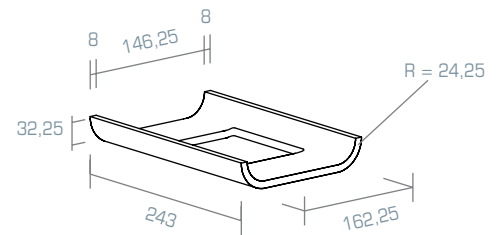

ART. 4709

SISTEMA BECCO DI CIVETTA
BULLNOSE SYSTEM
SYSTEME BORD ARRONDI
STEHSOCKELSYSTEM

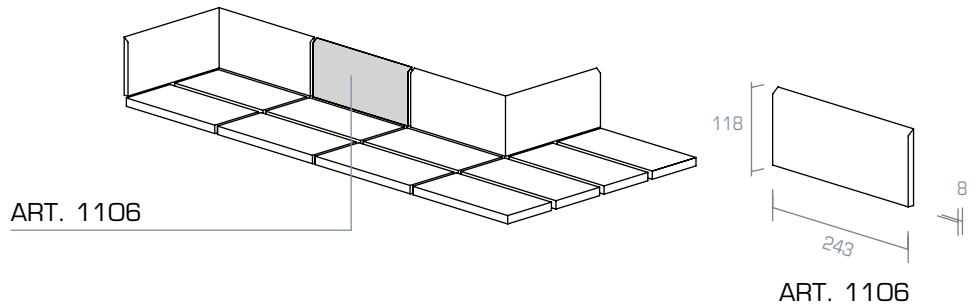

Colori: Colours: Couleurs : Farben: **Bianco avorio, Bianco B** Superficie: Surface: Surface : Oberfläche: **Matt**

Colori: Colours: Couleurs : Farben: **Tundra 100, Beach 101** Superficie: Surface: Surface : Oberfläche: **Satin**

SISTEMA ZOCCOLO
A RACCORDO SMUSSATO
COVE BASE SYSTEM
WITH BEVELLED TOP
SYSTEME PLINTHE
A GORGE BISEAUTE
HÖHKEHLSOCKELSYSTEM
MIT ABGERUNDETER KANTE

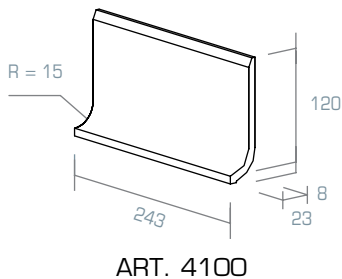
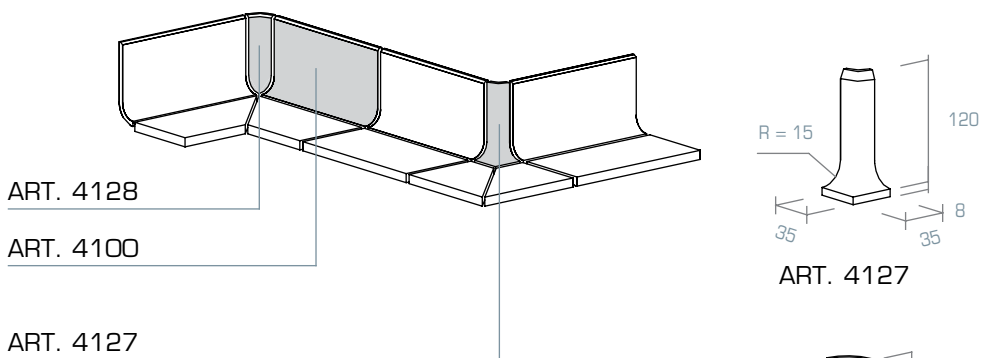

ART. 4128

ART. 4100

ART. 4127

Colori: Colours: Couleurs : Farben: **Bianco avorio, Bianco B**
 Superficie: Surface: Surface : Oberfläche: **Matt**

Colori: Colours: Couleurs : Farben: **Tundra100, Beach 101**
 Superficie: Surface: Surface : Oberfläche: **Satin**

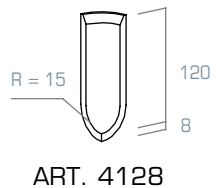

ART. 4128

SISTEMA SGUSCETTA COVE SYSTEM SYSTEME GORGE RINNENLEISTESYSTEM

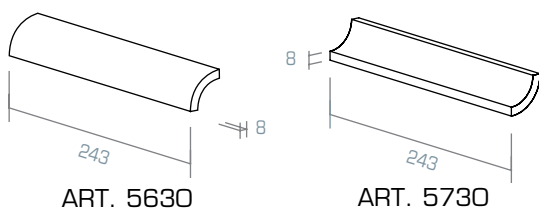

ART. 5630

ART. 5730

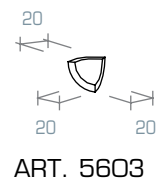

ART. 5603

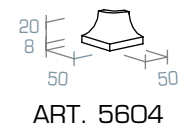

ART. 5604



ART. 5607

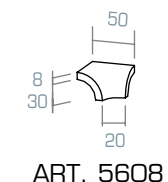

ART. 5608

Colori: Colours: Couleurs :
 Farben: **Bianco avorio, Bianco B**
 Superficie: Surface: Surface :
 Oberfläche: **Matt**

Colori: Colours: Couleurs :
 Farben: **Tundra 100**
 Superficie: Surface: Surface :
 Oberfläche: **Satin, Lucida**

Colori: Colours: Couleurs :
 Farben: **Beach 101**
 Superficie: Surface: Surface :
 Oberfläche: **Satin**

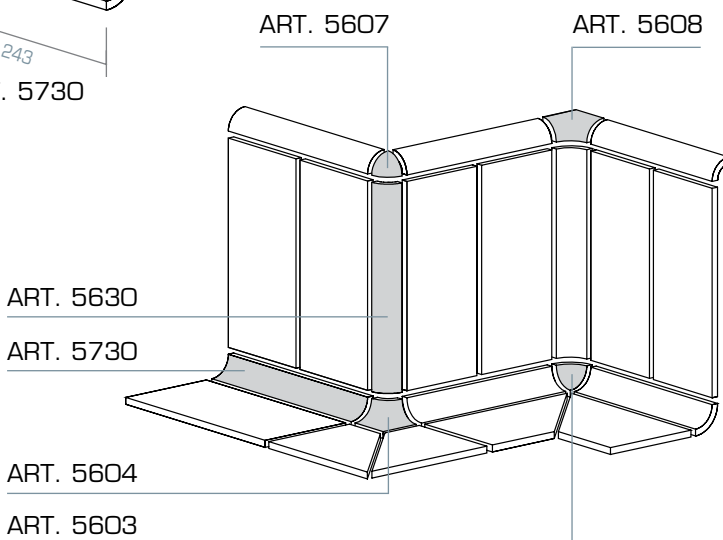

ART. 5607

ART. 5608

ART. 5630

ART. 5730

ART. 5604

ART. 5603

PEZZI SPECIALI TRIMS ACCESSOIRES FORMSTÜCKE

MODULO **20X20**

BATTISCOPA BULLNOSE
PLINTE À BORD ARRONDI
STEHSOCKEL
cm **10x20** - 4"x8"
cm **9x30** - 3½"x12"

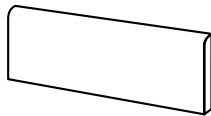

GRADINO STEP TREAD
NEZ DE MARCHE
STUFENPLATTE
cm **30x30** - 12"x12"

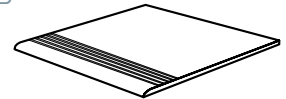

ZOCCOLO A RACCORDO A TAGLIO RETTO
COVE BASE - STRAIGHT TOP
PLINTE À GORGE AVEC BORD VIF
HOHLKEHL SOCKEL (SCHARFKANTIG)
cm **10x20** - 4"x8"

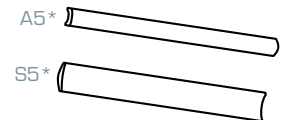
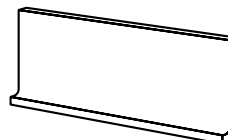

cm **2,5x20** - 1"x8"

ZOCCOLO AD APPOGGIO SMUSSATO
SIT-ON SKIRTING - BEVELLED TOP
PLINTE À TALON AVEC BORD ARRONDI
AUFSETZSOCKEL MIT ABGERUNDETER KANTE
cm **10x20** - 4"x8"

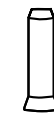
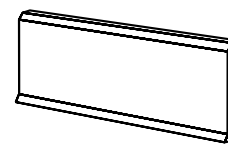

SGUSCETTA COVE
GORGE RINNLEISTE
cm **4x20** - 1½"x8"

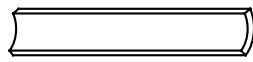

A1

S1

ANGOLARE
LONGITUDINAL
ANGLE
ANGULAIRE
SCHENKELPLATTE
cm **20x5x5** - 8"x2"x2"

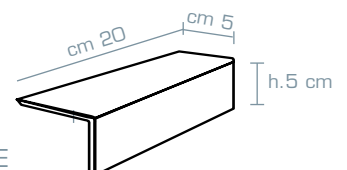

CARATTERISTICHE TECNICHE TECHNICAL FEATURES CARACTÉRISTIQUES TECHNIQUES TECHNISCHE EIGENSCHAFTEN



	NORMA STANDARDS NORME NORM	RISULTATO PROVA* TEST RESULTS* RESULTATS DES ESSAIS* ERGEBNISSE*
Classificazione prodotto Product classification Classement Klassifizierung	UNI EN 14411-G ISO 13006	Gruppo B1a UGL completamente greificato Group B1a UGL fully vitrified Group B1a UGL grès cérame fin Gruppe B1a UGL Feinsteinzeug
Caratteristiche dimensionali e d'aspetto Dimensional and surface quality Caractéristiques de la surface Oberflächenqualität	UNI EN ISO 10545-2	Tolleranze minime nella 1ª scelta Very low tolerance Des tolérances minimales en 1er choix Entspricht Normen
Assorbimento di acqua Water absorption Absorption d'eau Wasseraufnahme	UNI EN ISO 10545-3	≤ 0,1%
Resistenza alla flessione Flexural strength Résistance à la flexion Biegezug-Festigkeit	UNI EN ISO 10545-4	N/mm ² 50±60
Resistenza al gelo Frost resistance Résistance au gel Frostwiderstandsfähigkeit	qualsiasi norma all standards toute norme Alle normen	Garantita Guaranteed Garantie Frostsicher
Resistenza attacco chimico (esclusione acido fluoridrico) Resistance to acids and alkalis (with the exception of hydrofluoric acid) Résistance à l'attaque chimique (exclusion de l'acide fluorhydrique) Säure und Laugen Beständigkeit (mit Ausnahme von Fluorwasserstoff)	UNI EN ISO 10545-13	Nessuna alterazione No damage Non attaquées Nicht angegriffen
Resistenza usura e abrasione Wear and abrasion resistance Résistance à l'usure et abrasion Abriebhärte		Illimitata Adequate for all purposes Illimitée Unbegrenzt
Dilatazione termica lineare Linear thermal expansion Coefficient linéaire de dilatation thermique Lineare Wärmeausdehnung	UNI EN ISO 10545-8	6 x 10 ⁻⁶
Resistenza alle macchie Stain resistance Résistance aux taches Fleckenfestigkeit		Garantita Guaranteed Garantie Garantiert
Resistenza alla scivolosità Slip resistance Résistance au glissement Trittsicherheit	DIN 51130	Vedere singole superfici See every surfaces Voir les durfaces une per une Siehe einzelne Oberflächen
	D.M. N° 236 del 14.06.89	valore μ > 0,40
Resistenza dei colori alla luce Light fastness Résistance de la couleur à la lumière Unveränderlichkeit der Farben wenn Strahlung zugesetzt wird	DIN 51094	Nessuna variazione No change of colours Couleurs inchangées Keinerlei Farbänderung



Si rimanda all'elenco prodotti UPEC ufficiale, consultabile sul sito:
Please see the official UPEC product list:
Veuillez consulter la liste officielle produits UPEC:
Siehe die offizielle UPEC-Produktliste auf der Website:
<http://webapp.cstb.fr/upec-ceramique/>

* Valore indicativo. Approx value.
Donnee approximative. Ungefähre Werte.
** Test made on Granito 1, Arizona Matt.
*** Test made on Marte Series.

PULIZIA PAVIMENTI ANTISCIVOLO CLEANING SLIP-RESISTANT TILED FLOORS NETTOYAGE DES CARREAUX ANTIDÉRAPANTS REINIGUNG VON TRITTSICHEREN BÖDEN

Sulle piastrelle antiscivolo, impiegate normalmente in ambienti industriali o di lavoro in genere, bisogna tenere presente gli specifici problemi di pulizia, legati al fatto che la superficie è strutturata in rilievo.

Le piastrelle di **Granitogres** in rilievo antiscivolo rappresentano per questi ambienti la soluzione ottimale che combina le esigenze dell'antiscivolosità con quelle dell'igiene. Per la pulizia dei pavimenti in rilievo di maggiore estensione occorre utilizzare macchine lavapavimenti a spazzole a dischi controrotanti, o anche macchine a rullo.

Nelle macchine a spazzole l'alternanza del senso di rotazione fa sì che le setole restino sempre perpendicolari, in modo da raggiungere sempre le cavità tra i rilievi.

È fondamentale l'uso di dischi con spazzole a setola dura (ad esempio Scotch-Brite verde 3M).

Altro metodo usato in questo tipo di pavimenti è quello mediante idropulitrice.

Slip-resistant tiles will normally be used in industrial or work areas and, because of the relief texture of the surface, can have special cleaning problems or needs. In these specific industrial settings, **Granitogres** slip-resistant tiles offer the optimum solution combining slip-resistance with good cleaning performance.

Three counter rotating brush or roller mechanical washers have proven excellent for cleaning extensive textured surface tiled floors. With 3-brush machines, the reciprocating scrubbing action ensures that the brushes are always perpendicular and, hence, reach all the way down to bottom of the texturing ridges.

Use of hard bristle brush disks is essential (for example Scotch-Brite green 3M).

Another commonly used method is the high pressure washer.

En ce qui concerne les carreaux antidérapants, utilisés en général dans les usines ou les ateliers, il convient de prendre en compte les problèmes spécifiques de nettoyage liés au fait que la surface est en relief.

Les carreaux de **Granitogres** en relief antidérapant représentent la solution idéale, combinant les exigences de glissance et d'hygiène. Pour le nettoyage des sols en relief sur de grandes surfaces, il convient d'utiliser des machines à brosses à disques rotatifs alternés ou des machines à rouleaux.

Dans les machines à brosses, l'alternance du sens de rotation permet aux poils de rester toujours perpendiculaires, afin d'atteindre les cavités entre les reliefs.

L'usage de disques équipés de brosses à poils durs (par exemple Scotch-Brite vert 3M) est fondamental.

Une autre méthode consiste à utiliser des machines de nettoyage à l'eau sous pression.

Bei trittsicheren Fliesen, die in der Regel in der Industrie oder an Arbeitsplätzen verwendet werden, muss man die spezifischen Reinigungsprobleme berücksichtigen, die damit verbunden sind, dass die Oberfläche strukturiert ist und ein Relief aufweist.

Die Fliesen aus **Granitogres** mit trittsicherer Oberfläche stellen für diese Räume eine optimale Lösung dar, denn sie vereinen Rutsicherheit mit Hygieneanforderungen.

Für die Reinigung von großflächigen Fußböden mit Reliefstruktur haben sich Reinigungsmaschinen mit gegenläufigen Bürstenscheiben oder auch mit Bürstenwalzen bestens bewährt.

Bei den Bürstmaschinen sorgt die abwechselnde Drehrichtung dafür, dass die Borsten immer senkrecht stehen und dadurch alle Hohlräume zwischen den Relieftteilen erreichen.

Wichtig ist die Verwendung von Bürstenscheiben mit harten Borsten (zum Beispiel Scotch-Brite grün 3M).

GRANITOGRES
TECHNIC
grès fine porcellanato



CASALGRANDE
PADANA
Pave your way



CASALGRANDE
PADANA
Pave your way

CASALGRANDE PADANA

via Statale 467, n. 73, 42013 Casalgrande (Re), Italy
tel + 39 0522 9901 - fax + 39 0522 996121
info@casalgrandepadana.it - www.casalgrandepadana.com

